

## Wireless Sensor System



The Wireless Sensor system includes sensor transmitters and a wireless receiver module attached to the Shuttle or Station Stopper. A magnet on the train is required to trigger the sensors.

### Wireless Transmitters

The wireless system includes two wireless sensors which are pre-configured. These operate with a 9V battery that should last well over a year, so removing the battery is not necessary when trains are not running. The train will carry a magnet that will trigger the sensors.

Both the wireless transmitter units, and the receiver board will blink blue when a train has been detected. Please protect the transmitter modules from moisture.

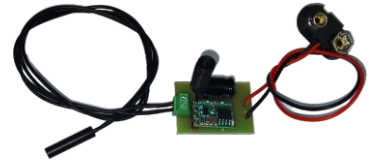

### Wireless Receiver - Cable Attachments

The wireless receiver module is attached to the unit with the two cables provided.

- The 2 pin cable attaches to the 2 pin header next to the sensor connector. There is no polarity, so install in either orientation.
- The 4 pin cable is attached to the 4 pin header behind the sensor connector. **Install with the black wire away from the 2 pin connector.** The polarity must be correct to operate, but the receiver board will not be damaged if installed backwards.

2 Pin connector goes here.  
**Any orientation.**

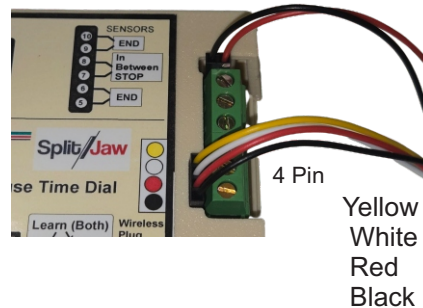

### Wireless Receiver Module Cable Attachments

The cables are pre-installed, but should they become detached, Install as shown.

- The 2 pin cable attaches to the 2 pin header in any orientation.
- The 4 pin connector attaches to the 4 pin header **Installed with the black wire towards the 2 pin connector.** The bottom of the PC board also notes the location of the black wire.

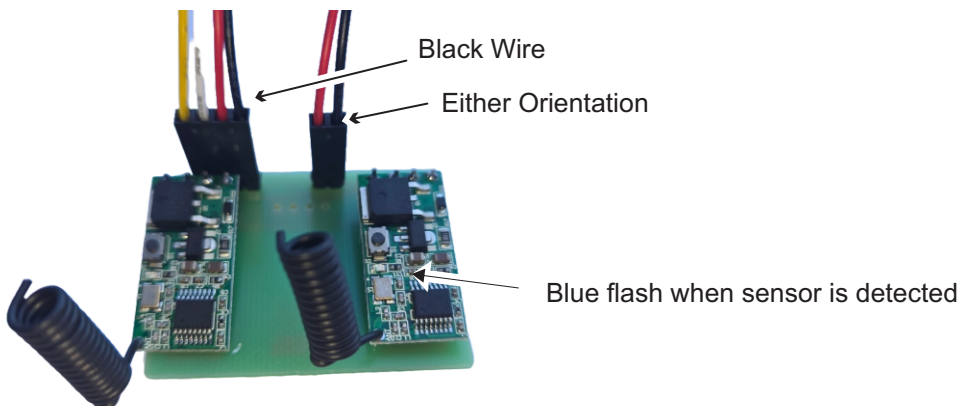

When a sensor is triggered, a blue flash should occur on the transmitter, and also on one of the receiver module boards.

On the Shuttle system, left / right location matters. If the Shuttle does not respond to the sensor, then swap the location of the sensors.

On the Station Stopper, the sensors are labeled as DECEL and STOP. The STOP sensor is optional, however the DECEL sensor is required to perform a station stop.

## Programming Wireless Sensors

The Shuttle and Station Stoppers is shipped with two wireless sensors which have already been programmed, however it is possible to add, replace, or remove sensors at any time.

Similar to garage door openers, sensor transmitters are 'married' to a receiver. However, this has already been done for you.



All programming is done on the Receiver Board and the transmitters are not programmed. The Receiver Board contains up to three modules, each with their own programming pushbutton. The two outer modules are the end sensors on a Shuttle, or the DECEL and STOP sensors on a Station Stopper, The center module is the optional in-between stop receiver for a Shuttle. (The center receiver module is not shown below, and is an add-on) The bottom of the PC board identifies the DECEL and STOP modules for a Station Stopper.

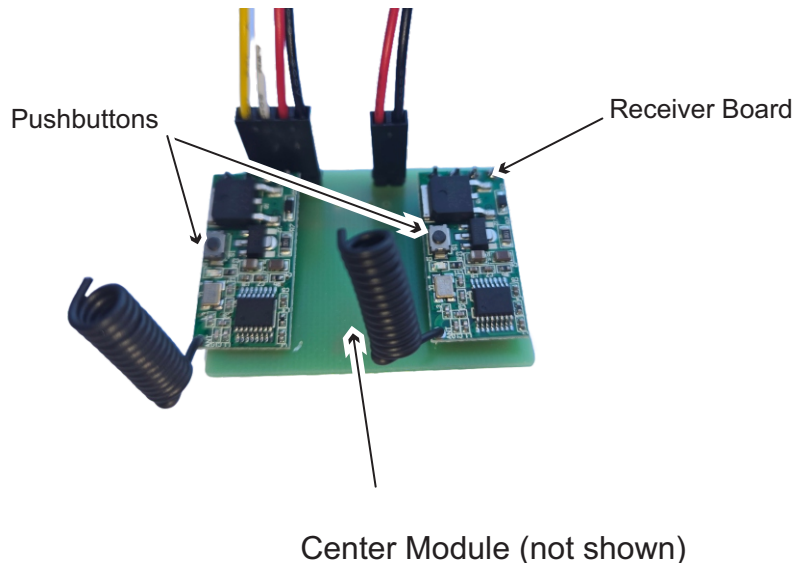

*For all programming, the main unit (Shuttle or Station Stopper) must be connected and powered up to provide voltage.*

### Erase All Connections on a Module

To erase all connections on a module, PRESS THE PUSHBUTTON EIGHT (8) TIMES. The module will respond with several blinks. Repeat this for each module you wish to program.

### Connect a Transmitter to a Module

One or many transmitters (sensors) can be married to a receiver. Perform these steps to marry a transmitter to a receiver:

- 1) Locate the desired module on the receiver board.
- 2) Obtain a magnet to trigger the train sensor on the transmitter.
- 3) PRESS THE PUSHBUTTON ON THE APPROPRIATE MODULE ONCE. After 2 seconds the blue LED will come on.
- 4) Trigger the train sensor with a magnet. The receiver will respond with several blinks indicating a connection.

Repeat for each train sensor, programming the appropriate receiver module. The receiver will blink blue when a signal has been received. If more than one module blinks when a sensor is triggered, then programming must be erased on the incorrect module, and then the module must be re-programmed with the appropriate sensor.