



Self-Adjusting SHUTTLE

Back-N-Forth

V5: Sensors and Programmable

The RR Concepts SHUTTLE can perform hands-off, back-and-forth operations using realistic accelerations and decelerations. Using sensors at the ends, no programming or adjusting is needed. Just place the train on the track and power up.

The RR Concepts SHUTTLE can control DC trains or DCC trains when used with a *PWM to DC conversion unit*. Any scale train can be run with a magnet installed on the engine.

Before we Start- Please do not attach power wires (from your power pack or transformer) to any other terminals except the designated input pins 1 and 2. Your SHUTTLE will be damaged if power is put on any terminal other than 1 and 2. The SHUTTLE will only operate when the input voltage polarity is correct. It will not be damaged when reversed.

ONLY ATTACH WIRES WHILE THE POWER IS OFF.

Quick-connect terminals allow easy swap-out and removal of the electronics while leaving the wires in place. The RR Concepts Magnet/Screwdriver tool is recommended for wire-up and testing.

See decal on bottom for Instructions

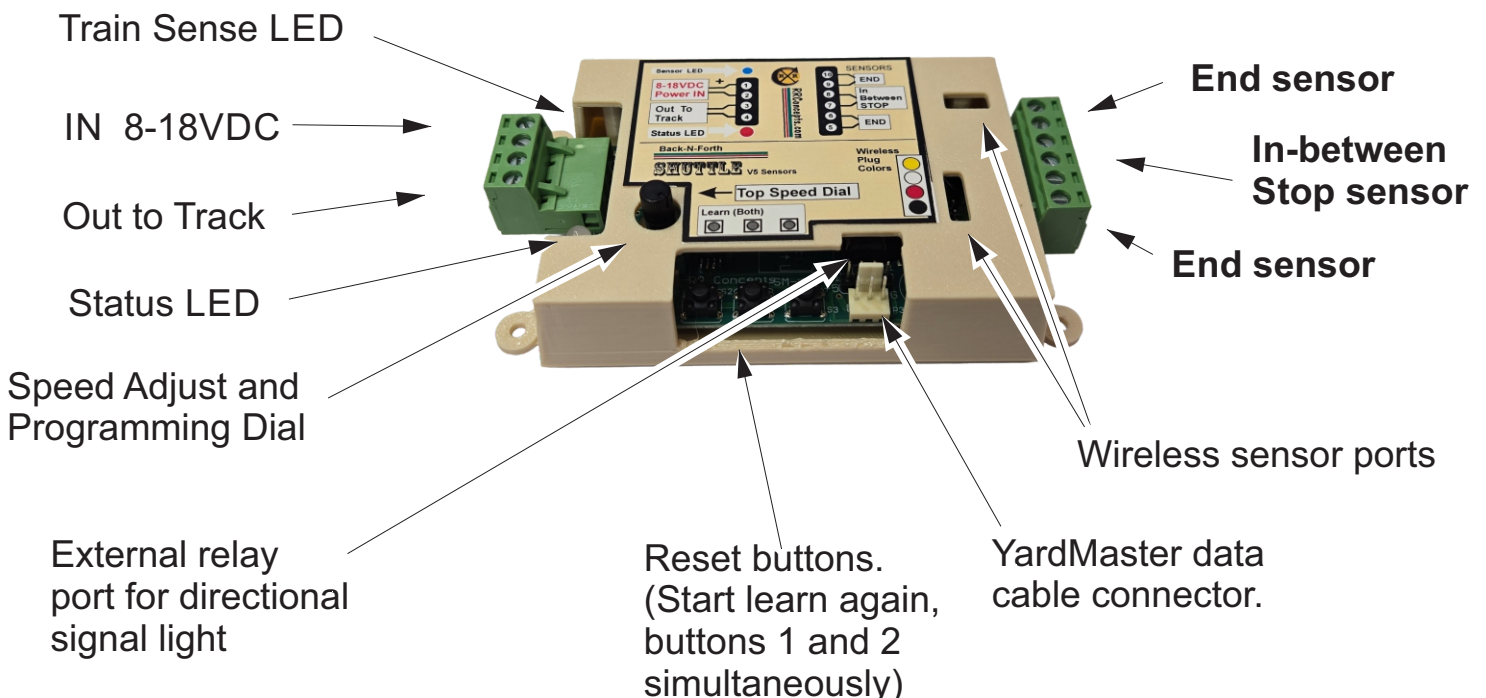



RR Concepts

Self-Adjusting SHUTTLE

Hookup Instructions

The Shuttle works with all DC trains, or DCC trains when a PWM to DC converter is installed. AC trains cannot be controlled.

Hookup for Self-Adjusting Accelerations and Decelerations

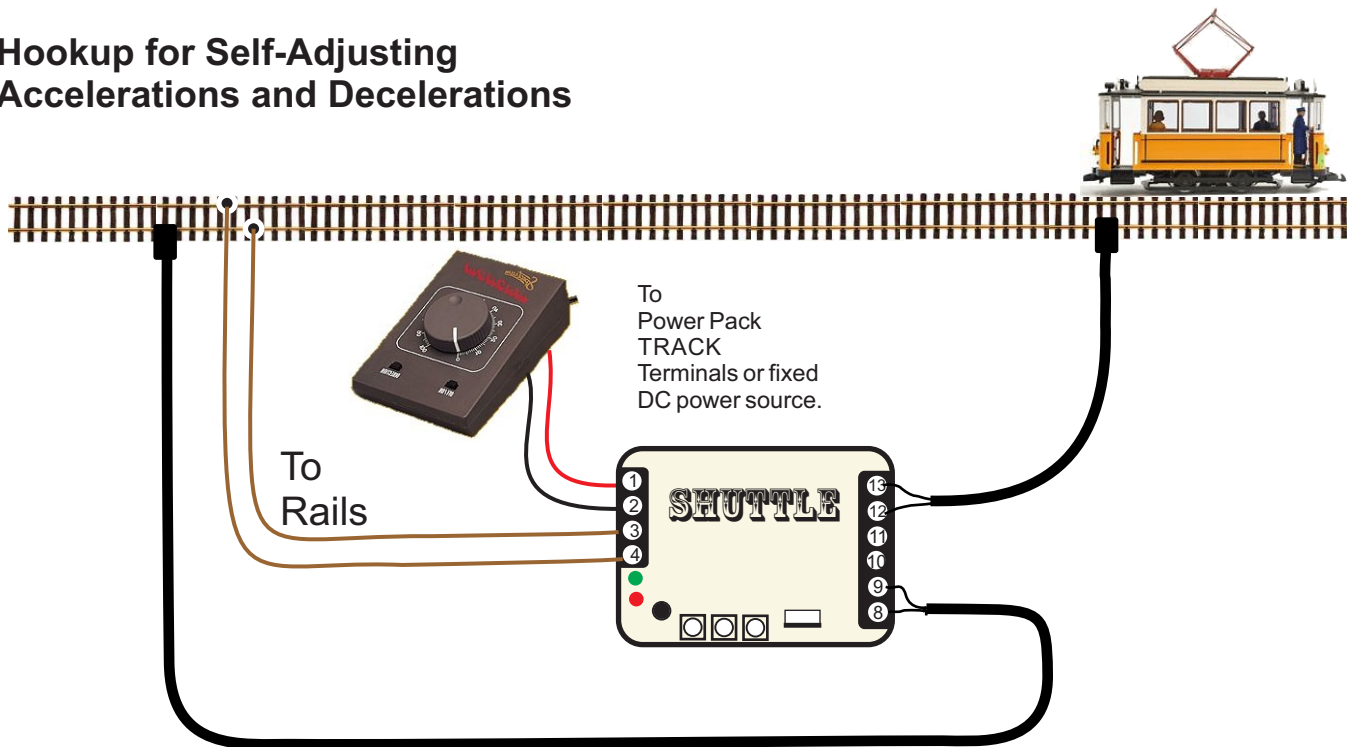

Hookup Instructions:

- 1) Attach terminals 1 & 2 to the transformer, TRACK output.
- 2) Attach terminals 3 & 4 to the rails. No polarity.
- 3) Attach sensors to the end sections as shown above. This is where the train will stop. If the train does not stop after passing the sensor then either swap the sensor locations, or swap the wires in pins 3 and 4. The sensors are reed switches and operate best when the magnet passes over the tip of the sensor.
- 4) Turn the transformer up to the desire speed of the train. If the desire speed is very slow (below 8 volts) the Shuttle may not be able to operate. In this case, turn the transformer up to a faster speed and use the top speed dial to slow down the train.
- 5) Sit back, and watch! The Shuttle will run back-and-forth, self-adjusting each time until a perfect run is obtained. It might stop short, or run too fast, but will settle in to a nice run after a few cycles.

Additional programming features include in-between stops, super smooth operations, alternating trains, changing the acceleration and deceleration rates, and more.



Operations

Self-Adjusting SHUTTLE

Instructions: **Let the train run and watch!**
Here's what is happening inside the box:

Learning Mode:

After a reset the Shuttle will restart the learn operation. The Shuttle will run the train back-and-forth for three times, measuring the distance between the ends. If no train is sensed for the first 10 seconds, then the Shuttle will reverse and run in the other direction. This could be the case where the train starts up in a diode section if they are present. While in learn mode the **blue LED** will be on.

Running Mode:

After learning is complete the Shuttle will self-adjust **each time** until a perfect run is obtained and the train is running realistically. The self-adjusting allows anyone to change the speed of the train, and the Shuttle will self-adjust to the new speed. The train may stop short a few times, or come to the ends faster than expected, but the Shuttle will eventually run perfectly and realistically. When running automatically the green, red, and orange LEDs will turn on.

Creeping Into the Ends:

When approaching the ends, the Shuttle will decelerate the train and then creep until reaching the end. The length of time for creeping is determined by the deceleration rate. A faster deceleration will result in a shorter creep, while a slower deceleration (more blinks) will creep longer. Adjust to what looks good since each train or trolley will behave differently.

Top Speed Adjustment:

The top speed of the train is set by either adjusting the transformers throttle, or by using the top speed dial. In some trains the lights and smoke will stay on when running slowly if the transformer throttle is set high and the top speed dial is used to slow down the train.

Pressing Buttons #1 and #2 will reset the Shuttle and start the learning process again. This is not a factory reset, but only a "start over" operation.

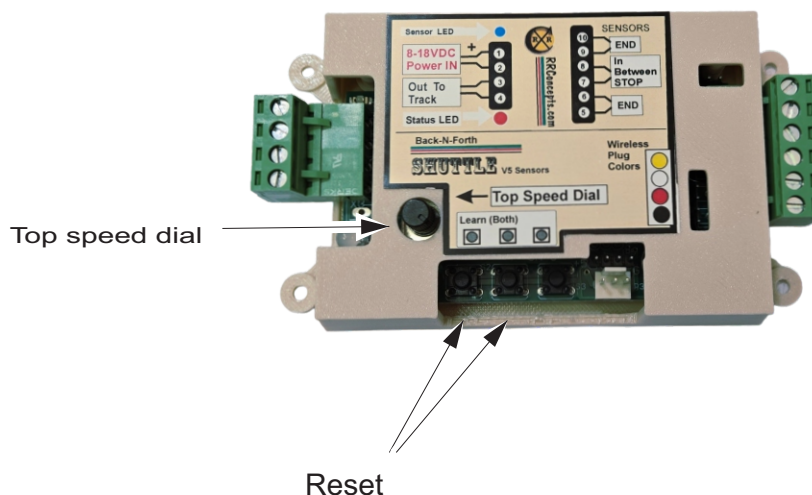



Input Power

The Shuttle is usually installed between the train transformer and the track, however a fixed DC power source could also be used. The Shuttle can accept voltages up to 18 volts, however a high-power version is available which can accept up to 24 volts.

In all cases the voltage should be pure DC and not “pulsed” or PWM. Some electronic speed controllers use pulsed voltage which may not be compatible with the Shuttle. Please use a “PWM to DC converter” if a pulsed transformer is used. If there is a momentum switch on the transformer then it is using a pulsed operation.

Variable Speed Transformer Hookup:

Attach terminals 1 & 2 to your transformer's DC output (Sometimes labeled as TRACK) and set the throttle to the running speed of the train. If the running speed of the train is very slow (under 8 volts), then turn up the throttle on the transformer and use the top speed dial on the Shuttle to reduce the train speed. ***If the Shuttle does not light up then reverse the direction on the transformer.***

Fixed Voltage Source Hookup:

Since the Shuttle controls the speed of the train, a variable speed transformer is not required and a fixed DC power source could be used. Usually a 12 volt DC power source is a perfect solution and these can be obtained quite inexpensively. Attach the voltage source to pins 1 and 2 and use the top speed dial on the Shuttle to set the running speed of the train. If the Shuttle does not light up then reverse the wires on pins 1 and 2.

Output Conenction

Connect terminals 3 and 4 to the track, either rail.

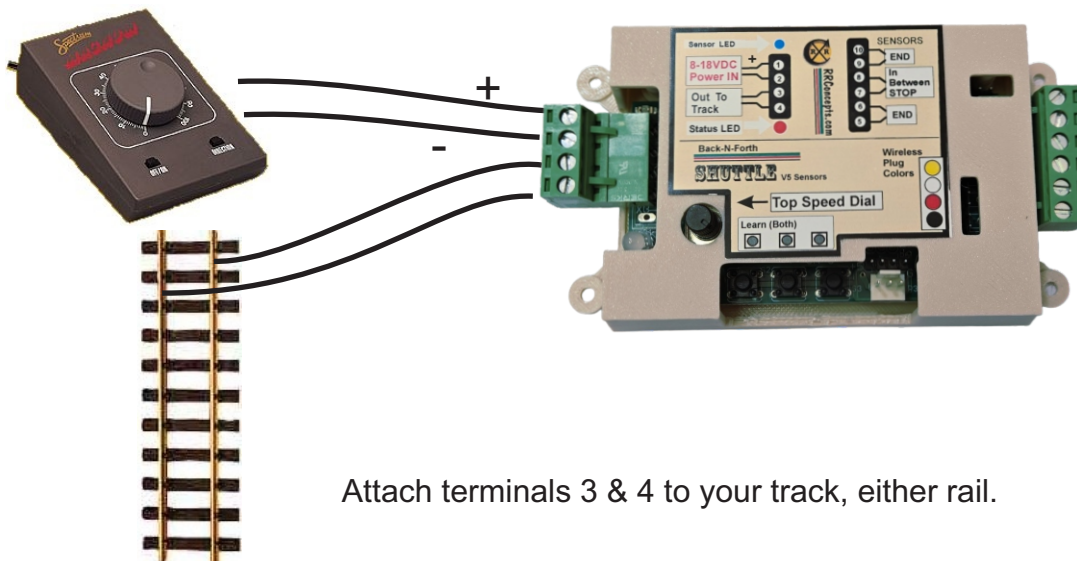

Attach terminals 3 & 4 to your track, either rail.

RR Concepts

In-Between Station Stops

For in-between stops, attach a sensor to the in-between stop terminals. When the magnet on the train triggers the sensor the train will pause at the station. For more than one stop add more sensors in parallel.

Note that The deceleration rate is rapid and the time duration for the stop is fixed. This allows the train to stop at approximately the same location for each direction.

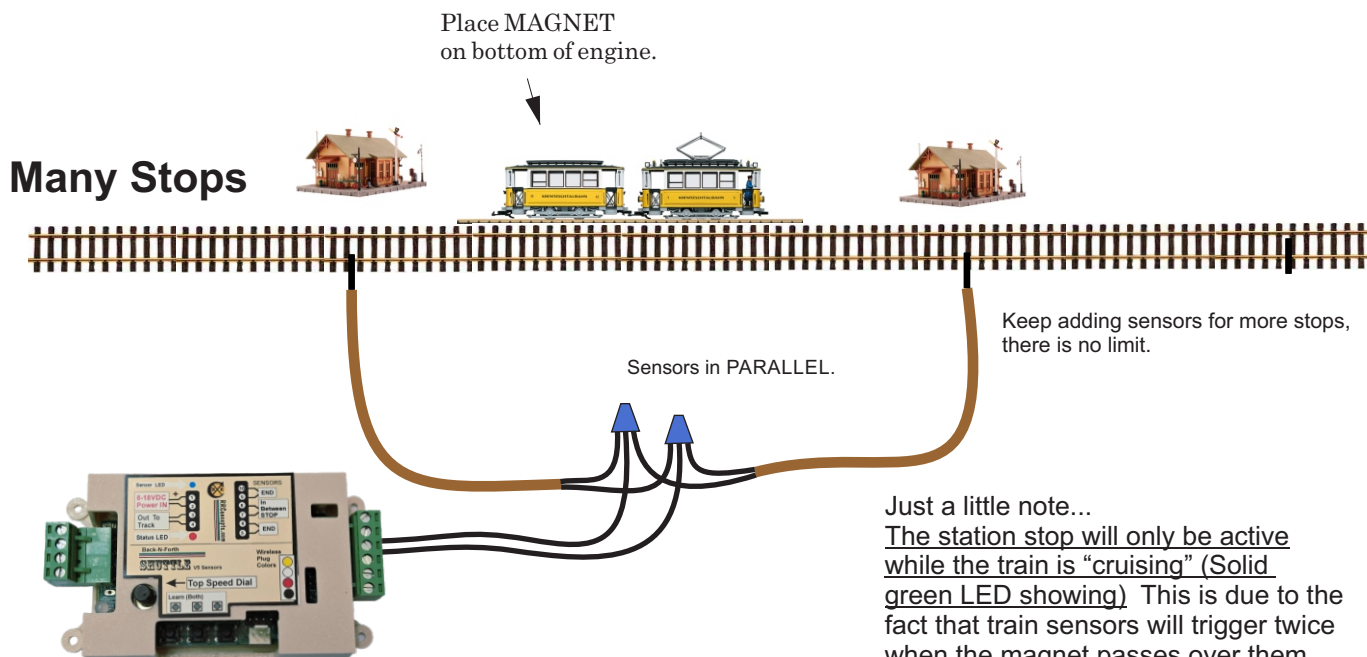
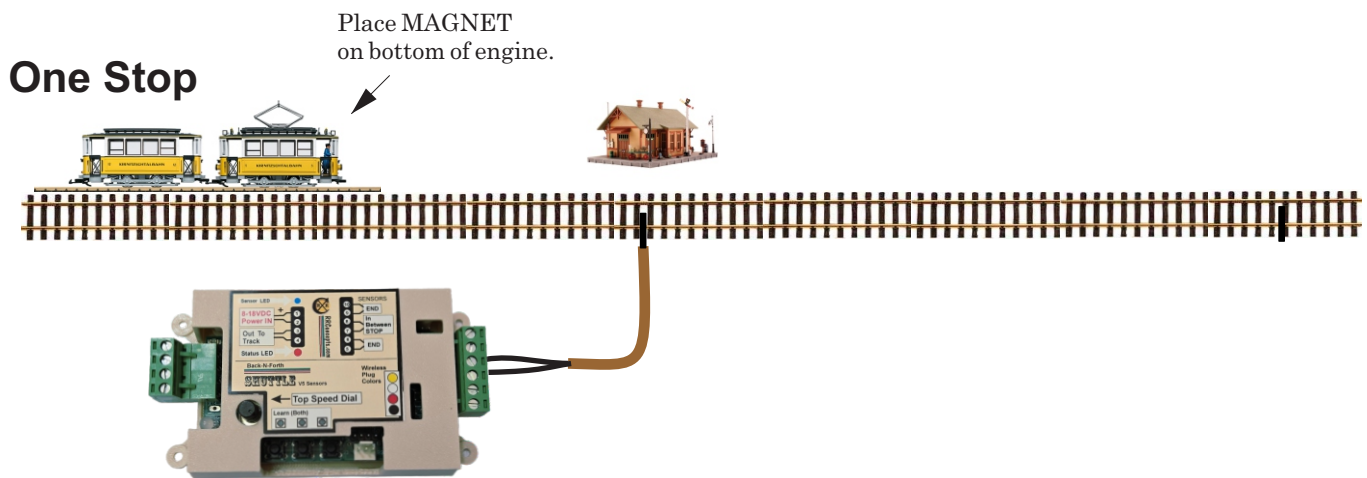

Just a little note...
 The station stop will only be active while the train is "cruising" (Solid green LED showing). This is due to the fact that train sensors will trigger twice when the magnet passes over them. This allows you to run really slowly and not have false triggers while accelerating.

Top Speed and Programming Mode Dial

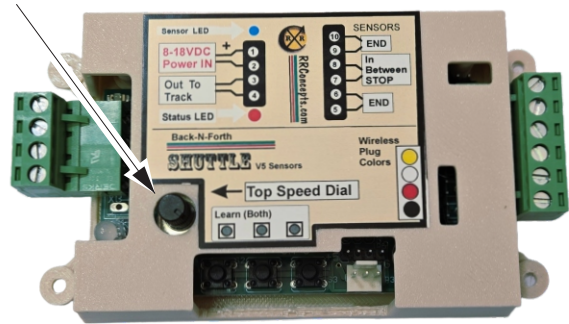

The Top Speed dial provides 2 functions:

- 1: Adjust the top "cruising" speed of the train when in automatic mode.
- 2: Enter programming mode.

Automatic Mode **Top speed** adjustment

"Full speed" is clockwise. Turn this dial down as necessary to set the desired cruising speed of the train. This is only necessary when using a fixed voltage power supply or when a very slow top speed is desired.

Typically, this dial is set fully clockwise and the train throttle (transformer) is used to set the speed of the train.

Programming Mode

To enter programming mode turn this dial fully counter-clockwise. The blue Train Detect LED will "twinkle" to indicate "programming mode".

To exit programming mode turn the dial fully clockwise.

Make sure the train is clear of all sensors when entering programming mode. Pushbuttons and sensors are internally wired together so a sensor would behave identical to a pushbutton.



RR Concepts

LED indicators

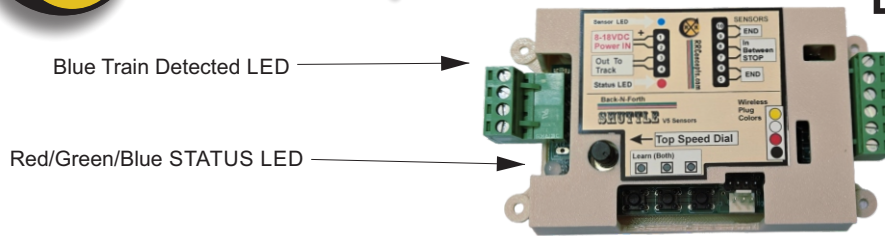

Status LED White. Train is running to an end for the first time. In-between stops will not happen. If a train is not sensed after 10 seconds the Shuttle will reverse.



Status LED Blue Not Flashing:
Shuttle is performing the learn operations.



Status LED Blue Flashing once a second: Shuttle is performing a time delay operation and is still self-adjusting. (See orange flashing)



Status LED Green:
Flashing: Train is accelerating.
Not Flashing: train is "cruising".



Status LED Red Flashing: Train is decelerating and operating normally.



Status LED Orange flashing quickly: Train is creeping into the diode section.



Status LED Orange flashing once a second: Shuttle is performing a time delay with self-adjusting completed.

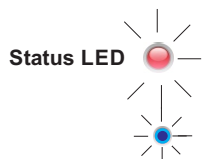

Status LED Red and blue blinking indicates a SHUTDOWN due to an **over-current** or **stalled** train. To recover: Turn power off then back on **or press and hold button #1**. If the condition returns after recovery then check for a short circuit on the track or turn off the shutdown feature.

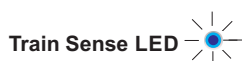

Train Sense LED Train Sense LED indicates a train is sensed. When **twinkling** the Shuttle is in programming mode. Turn the top speed dial clockwise to exit programming mode.

Programming: Deceleration Rate

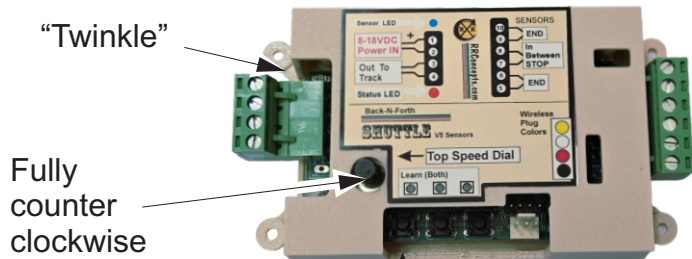

1. Make sure a train is clear of all sensors.
2. If the top speed dial is not already at zero, then turn the top speed dial to zero. (fully counter-clockwise.) The Blue "Train Detected" LED will "twinkle"
3. Push and hold programming button #1.
4. Watch the status led. Each RED blink will decelerate slower.

The fastest deceleration will be with one blink. (TRAIN Stops sooner) Release the pushbutton when the desired number of blinks have occurred. A typical number is 5. Repeat this procedure if you want a different value.

One blink corresponds to a 3 second deceleration rate. Each additional blink adds 1 second. For example, a blink count of 5 would result in a deceleration rate of 8 seconds.



The deceleration rate will also determine the creeping time. A longer deceleration will allow the train to creep for a longer duration before entering the stops.

When finished with all programming turn the *top speed* dial fully clockwise to exit programming mode, and then turn down to a desired top speed if needed.

All programming values are stored in flash memory and are retained on each power up.



Programming: Acceleration Rate

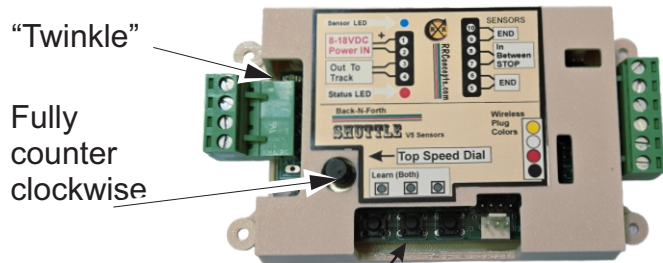

1. Make sure a train is clear of all sensors.
2. If the top speed dial is not already at zero, then turn the top speed dial to zero. (fully counter-clockwise.) The blue train Detected LED will “twinkle”.
3. Press and hold programming button #2..

4. Watch the status led. Each GREEN flash will accelerate slower.

The fastest acceleration will be with one blink.

Release the button when the desired number of blinks have occurred. A typical number is 5. Repeat this procedure if you want a different value. One blink corresponds to a 3 second acceleration time. Each additional blink adds 1 second. For example, a blink count of 5 would result in a acceleration rate of 8 seconds.

When finished with all programming, turn the *top speed* dial fully clockwise. All programming values are stored in flash memory and are retained.



A Note on Super Realistic Accelerations:

- * For blinks 1 thru 9 the train will accelerate smoothly with the programmed value. This is typical for trolleys.
- * For blinks 10 and above the train will creep very slowly out of the station for a few seconds and then accelerate up to full speed. This will only work with longer lengths of track where the train runs for 30 seconds or more.
- * 10 blinks will creep for 5 seconds.
- * 11 blinks will creep for 10 seconds.
- * 12 blinks and up will creep for 15 seconds.



RR Concepts

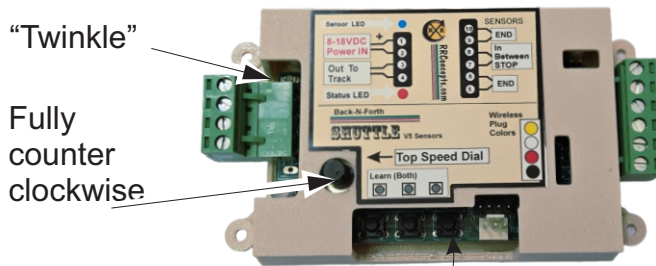

Programming: Pause Time

1. Make sure a train is clear of all sensors.
2. If the top speed dial is not already at zero, then turn the top speed dial to zero. (fully counter-clockwise.) The blue train Detected LED will “twinkle”.
3. Press and hold programming button #3.
4. Each ORANGE flash will increase the pause time on the ends.
A pause time of zero will be with one flash.
Release the button when the desired number of flashes have occurred.
Repeat this procedure if you want a different value.

The LED will turn orange when an infinite delay is set (after 13 counts).

When infinite delay is set, an “In Between Stop” sensor trigger is required to start up the train after stopping.

A fun thing to do would be to connect the In between stop terminals to a doorbell switch. Your train would patiently wait until someone pushed the button! Motion sensors are another possible way to start the train.



When finished with all programming increase the *top speed* dial clockwise to maximum or to a desired top speed. All programming values are stored in flash memory and are retained until re-programmed.

The number of orange FLASHES will correspond to the following time delays:

- 1: 0 seconds, no wait.
- 2: 5 seconds
- 3: 10 seconds
- 4: 15 seconds
- 5: 20 seconds
- 6: 30 seconds
- 7: 1 minute
- 8: 2 minutes
- 9: 5 minutes
- 10: 10 minutes
- 11: 30 minutes
- 12: 60 minutes
- 13: Infinite, wait for in-between stop sensor.



RR Concepts

Programming: Advanced Settings

GREEN

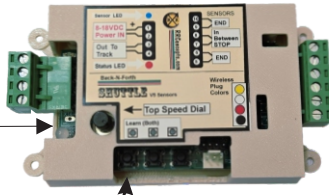

HOW TO PROGRAM:

- 1. Enter Secondary Programming mode:** (Skip this step if already in secondary programming mode)
 - * Turn the Top Speed dial fully counter-clockwise to enter programming mode (Skip this step if already in programming mode).
 - * Turn the Top Speed dial *slowly clockwise* until the LED turns **GREEN**. This indicates secondary programming mode. This should be about half-way.
- 2. To view the currently settings, quickly press button #1.**
To program a new setting, press and hold programming button #1 until the desired number of blinks have occurred. The Shuttle will echo the programmed settings when released.
 A green blink indicates the setting is ON, while a red blink indicates the setting is off.



Each blink will set or clear a different feature. If currently ON it will turn off. If OFF it will turn ON.

Programmable Settings: (Any or all of these or all can be programmed independently)

- Hold button for 1 blink = Resume Running on power up. Do not perform the learn operation on power up and resume all settings from last time. The default setting is ON.
- Hold button for 2 blinks = Super Realistic "Slow Creep" mode.
 The Shuttle will determine the absolute slowest speed that the train can achieve when entering the diode sections. This will take many more cycles to "dial in", but the result will be a very slow creep into the ends. The train will stop short many times but will always go to the sensors.
- Hold button for 3 blinks = Disable the shutdown. This is sometimes needed when a very small transformer is used which causes false shutdown errors. Notice that the Shuttle could be damaged if the shutdown is disabled while using a large power source.
- Hold button for 4 blinks = Double Siding 3 train operation. Send signals to a pair of YardMasters to perform a double siding three train operation.

When the button is released the Shuttle will echo the currently programmed settings with four blinks of either red or green.

For example, if "Resume Running on Power Up" has been set (one blink) and nothing else, then the Shuttle will echo

- blink 1 GREEN: "Resume Running" is ON.
- blink 2 RED : "Super Realistic Slow Creep" is OFF.
- blink 3 RED: "Disable the shutdown is" OFF
- blink 4 RED: "Double Siding" control is OFF.

A factory reset will set blink 1.



Programming: Factory Reset

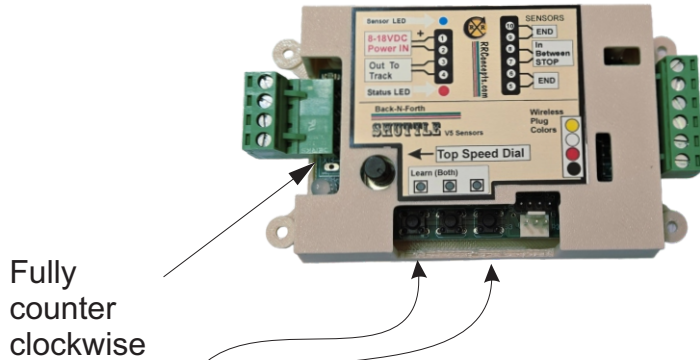

Fully
counter
clockwise

To set the Shuttle back to factory defaults perform the following:

- 1: Enter programming mode by turning the top speed dial fully counter-clockwise.
2. Press and hold both button #1 AND button #3 at the same time, then release buttons.
- 3 Turn the top speed dial fully clockwise to exit programming mode.

The factory default settings are:

- * Acceleration rate 2 blinks
- * Deceleration rate 3 blinks.
- * Time delay 10 seconds.
- * Train count: 1
- * Shutdown current: 3 AMPS
- * Operating modes:

Blink 1 = RED, Resume Running ON.
 Blink 2 = RED, Super Realistic Slow Creep: OFF.
 Blink 3 = RED, Disable overload shutdown: OFF.
 Blink 4 = RED, Three train reversing siding control: OFF.



Programming: Shutdown Current

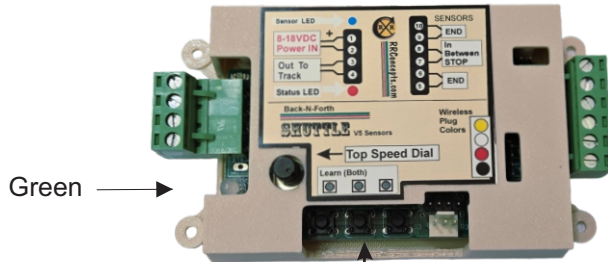

The Shutdown current should match the transformers current capability. This will allow the Shuttle to shut down on a short circuit condition which will occasionally happen. If set too high the Shuttle will not shut down and damage could occur. If the transformer already has short circuit protection then this should be set to maximum. For transformers which can supply 5 AMPS or more set to maximum. ***For transformers with less than 2 AMPS (LGB starter sets) just use the default of 3 AMPS for reliable operations.***

A factory reset will set this to 3 AMPS.

Programming:

1. Make sure a train is not on the in-between stop sensor.
2. If not already in programming mode, turn the top speed dial to zero. (fully counter-clockwise.)
3. Slowly turn the top speed dial clockwise until the LED turns GREEN. This indicates secondary programming mode. (Skip this step if already in secondary programming mode)
4. Press and release button #2 quickly to see the current setting, or press and hold button #2 for the desired number of blinks to set a new value. Each blink corresponds to 1 AMP, so 5 blinks would be 5 AMPS.

After the button is released the programmed value will be echoed back. Repeat this procedure if you want a different value.

When finished with all programming, turn the top speed dial clockwise.

All programming values are stored in flash memory and saved until re-programmed again.



Programming: Train Count

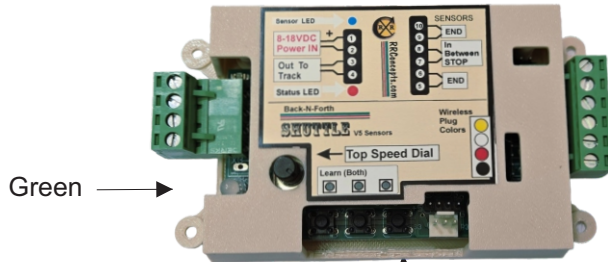

The train count is only needed when a YardMaster is attached. A train count will instruct the Shuttle to do the following:

1. Manage different creeping speeds for up to 3 trains.
2. Send proper signals to attached YardMasters to correctly fire turnouts.

A factory reset will set this to 1 train.

Programming:

1. Make sure a train is clear of all sensors.
2. If not already in programming mode, turn the top speed dial to zero. (fully counter-clockwise.)
3. Slowly turn the top speed dial clockwise until the LED turns GREEN. This indicates secondary programming mode. (Skip this step if already in secondary programming mode)
4. Press and release button #3 quickly to see the current setting, or press and hold button #3 for the desired number of blinks to set a new train count.

After the button is released the train count setting will be echoed back. Repeat this procedure if you want a different value.

When finished with all programming, turn the top speed dial clockwise.

All programming values are stored in flash memory and saved until re-programmed again.

External Relay / Signal Light Control

The Shuttle has a signal light header which can be used to control an external signal light relay. When a relay is attached, it will be ON when the train is traveling forward, and OFF when reversing.

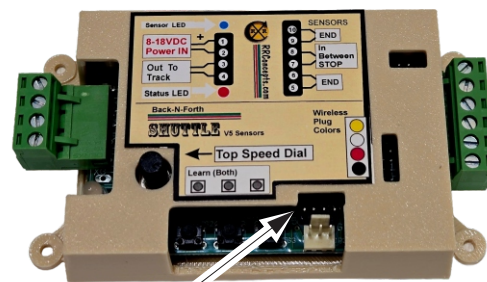

Signal Light Header
Turn connector around
if relay does not work



DPDT Auxilliary relay with cable
Available at RRConcepts.com



SHUTTLE

Wireless Sensor System

The Wireless Sensor system includes sensor transmitters and a wireless receiver board attached to the Shuttle.

Wireless Transmitters

The Wireless Shuttle includes two wireless sensors which are pre-configured for the ends.

These operate with a 9V battery that should last well over a year, so removing the battery is not necessary when trains are not running. The train will carry a magnet that will trigger the sensors.

Both the wireless transmitter unit, and the receiver board will blink blue when a train has been detected. Please protect the transmitter modules from moisture.



Wireless Receiver - Shuttle Cable Attachments

The wireless receiver board is attached to the Shuttle with the two cables provided.

- The 2 pin cable attaches to the 2 pin header next to the sensor connectors. There is no polarity, so install in either orientation.
- The 4 pin cable is attached to the 4 pin header next to the sensor connectors. **Install with the black wire away from the 2 pin connector.** The polarity must be correct to operate, but the receiver board will not be damaged if installed backwards.

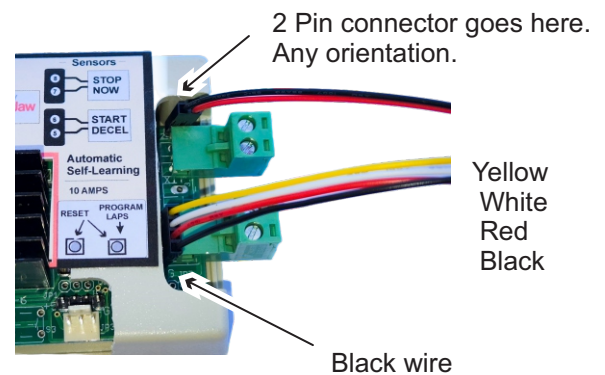

Wireless Receiver Board Cable Attachments

Install cables as shown.

- The 2 pin cable attaches to the 2 pin header in any orientation.
- The 4 pin connector attaches to the 4 pin header **Installed with the black wire towards the 2 pin connector.** The bottom of the PC board also notes the location of the black wire.

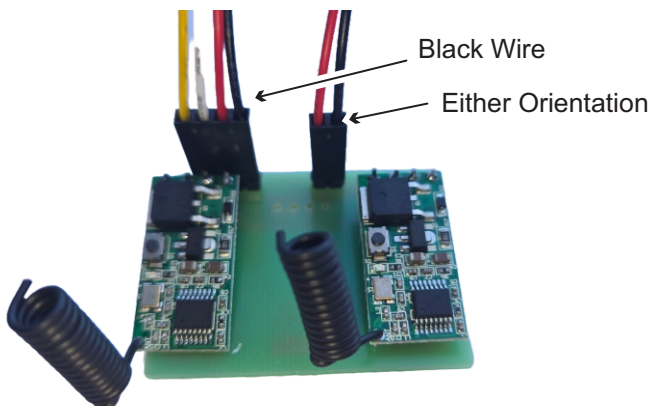

After the cables are attached and the sensors are placed on the ends, the Shuttle is ready to run!

When a sensor is triggered, a blue flash should occur on one of the receiver modules. If the Shuttle does not respond to the sensor, then swap the location of the sensors. Each sensor is programmed to only operate in one direction.

See "Programming wireless sensors" for more information on adding or replacing sensors.

SHUTTLE

Programming Wireless Sensors

The Reversing Shuttle is shipped with two wireless sensors which have already been programmed, however it is possible to add, replace, or remove sensors at any time.

Similar to garage door openers, sensor transmitters are 'married' to a receiver. However, this has already been done for you.



All programming is done on the Receiver Board and the transmitters are not programmed. The Receiver Board contains three modules, each with their own programming pushbutton. The two outer modules are the end receivers, and the center module is the in-between stop receiver. (The center receiver module is not shown below, and the in-between stop sensor is an add-on)

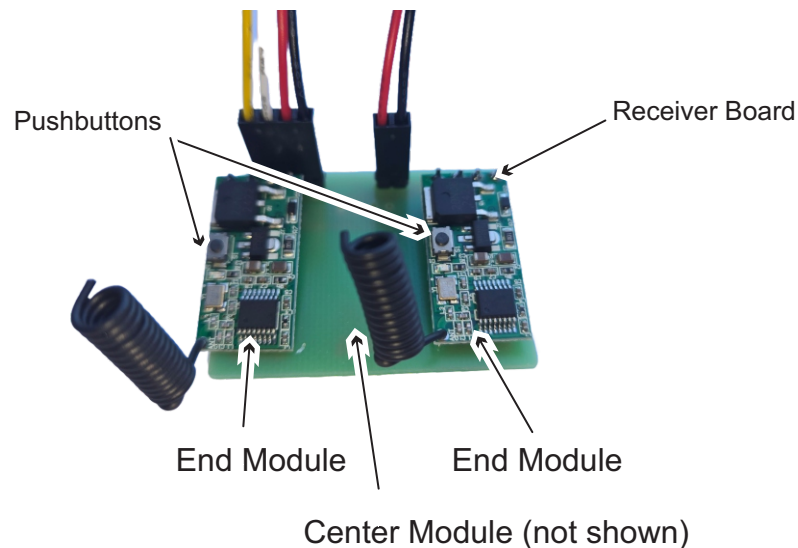

For all programming, the Shuttle must be connected and powered up to provide voltage.

Erase All Connections on a Module

To erase all connections on a module, PRESS THE PUSHBUTTON EIGHT (8) TIMES. The module will respond with several blinks. Repeat this for each module you wish to program.

Connect a Transmitter to a Module

One or many transmitters (sensors) can be married to a receiver. Perform these steps to marry a transmitter to a receiver:

- 1) Locate the desired module on the receiver board. (Ends or in-between stop modules)
- 2) Obtain a magnet to trigger the train sensor on the transmitter.
- 3) PRESS THE PUSHBUTTON ON THE APPROPRIATE MODULE ONCE. After 2 seconds the blue LED will come on.
- 4) Trigger the train sensor with a magnet. The receiver will respond with several blinks indicating a connection.

Repeat for each train sensor, programming the appropriate receiver module. The receiver will blink blue when a signal has been received. If more than one module blinks when a sensor is triggered, then programming must be erased on the incorrect module, and then the module must be re-programmed with the appropriate sensor.



Point to Point Reversing With a Siding

Two trains back-and-forth reversing, alternating.
Diode version shown. Replace diodes with sensors when running sensor units.

Requires an isolator on each siding, and diodes on each end.

T.

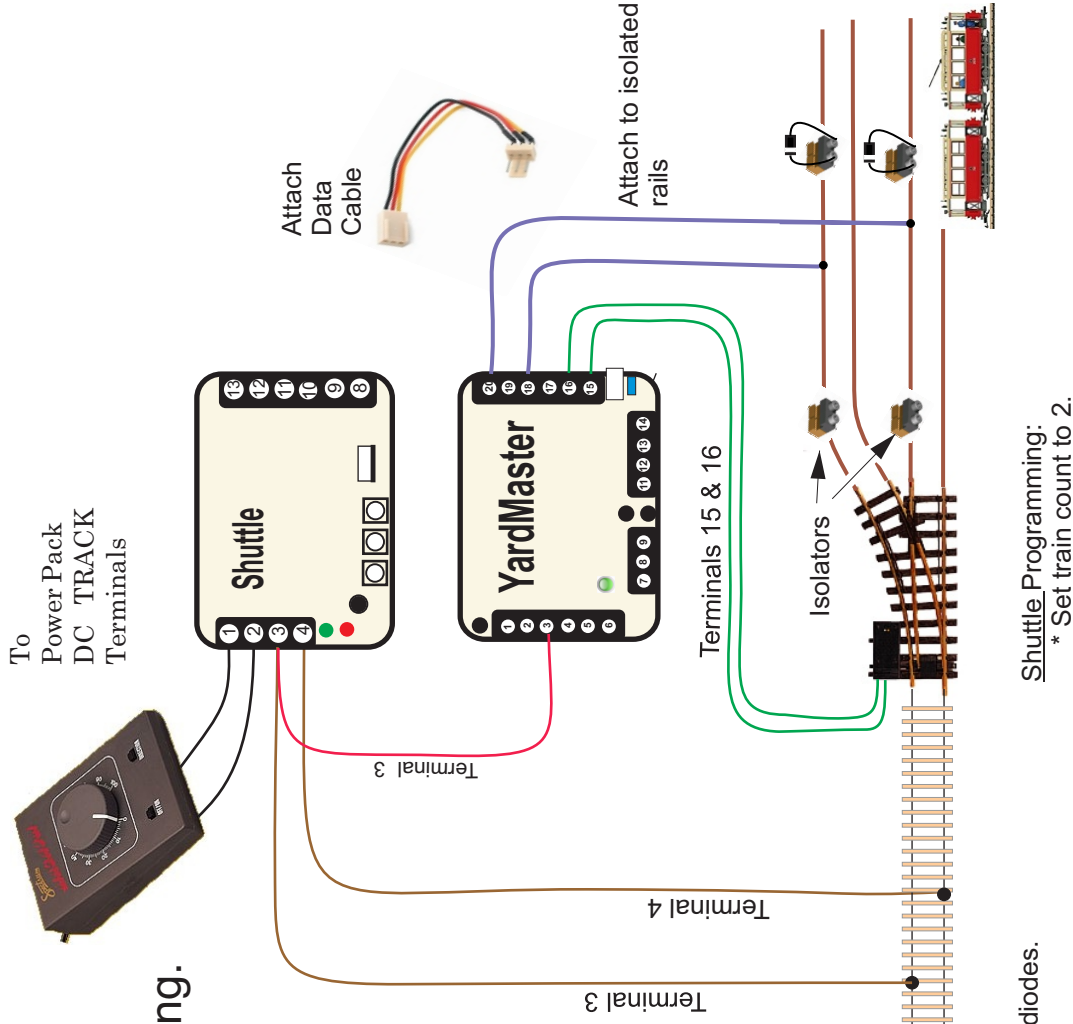

Isolators with diodes.
(3 places)
Swap the diode polarity if the train does not stop.

This rail has no isolators or diodes.

The YardMaster will only fire when the train is going "forward".
If the turnout switches on the wrong end then swap ALL the wires in Shuttle pins 3 and 4.



Reversing with Sidings on both Ends. 3 Trains running with acceleration & deceleration.

Two trains will be parked in sidings and one train will travel to the other side. After that train stops the adjacent train in the siding will travel to the location where the previous train left. This operation is repeated so that all three trains will travel back and forth.

Programming:

Set programming blink 4 to enable "double siding" operation.

Diode connections shown. Replace with sensors when running with sensor version of Shuttle

Parts Required:

- 1 Shuttle.
- 2 YardMasters.
- 4 Diode Isolators.
- 4 Track Isolators.
- 1 Y Data Cable



Connect Y data cable between StationMaster and both YardMasters

Pin 3 on all units connect together and attach to "main line" rail.

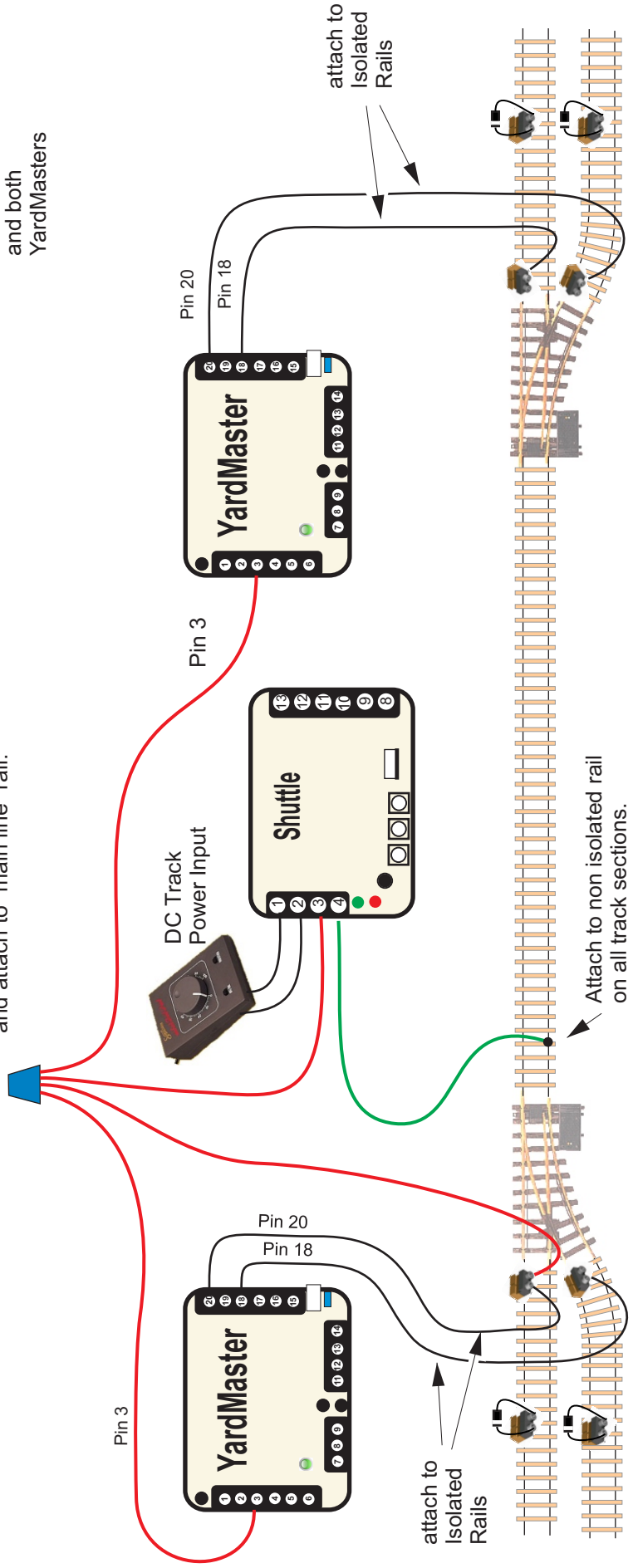



Sensor Placements on Track

The suggested sensor placement on track is shown below with the train magnet installed in the center of the train. Best sensing is done with the magnet passing over the tip of the sensor.

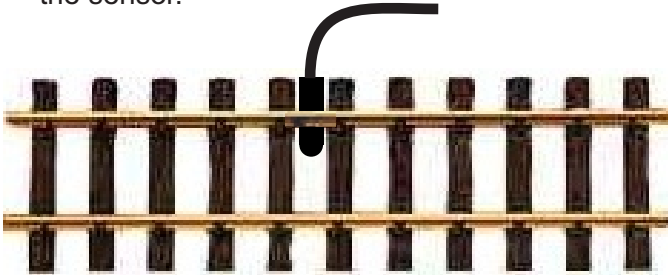

Sensor Placement for identifying a train for multiple train hookups.

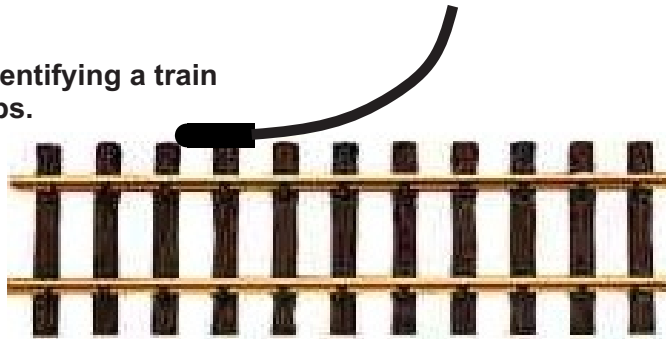

Offset the train's magnet to the same side as the sensor as shown.

For example, passenger trains have the magnet offset to the right and freight trains have the magnet offset to the left side.

Sensor placement for HO EZ track is under the roadbed.

